

mody

MHC SERIES - HI CHROME SLURRY SUBMERSIBLE PUMP

MHC4 SERIES

ELECTRIC SUBMERSIBLE SLURRY PUMP - 28% HI-CHROME DESIGNED FOR PORTABLE AND ABRASIVE APPLICATIONS

MODEL	HP	RPM	MAX.AMPS 230v / 460v 60Hz	SOLID HANDLING (in)	WEIGHT (lb)
MHC4/7.5	7.5	1800	19.4 / 9.7	1.4	330
MHC4/10	10	1800	25.0 / 12.5	1.4	370



MATERIALS OF CONSTRUCTION AND ENGINEERING DATA

PUMP END

pH Range	5 - 12
Impeller Type	Two Vane Semi-Open
Max. Temperature of Pumped Fluid:	104°F/40°C
Max. Starts/Stop Per Hour:	15
Max. Submergence:	65 Feet

MOTOR

4-pole induction **continuous rated** motor with squirrel cage rotor. Bi-metallic switches (thermals) embedded in stator winding to protect against overheating. Stator insulation class 'H' (180°C), 1.15 Service Factor.

POWER SUPPLY

3 phase, 60 Hz, AC Supply, 208, 230,460,575. Other voltages available upon request.

BALL BEARINGS

The rotor shaft is carried on a double row angular contact ball bearing which carries the high thrust and radial loads. The Upper bearing is a deep groove ball bearing. The bearings are enclosed with high temperature grease containing special Anti-corrosion additive.

POWER CABLE

Waterproof/oil proof, rubber-insulated, neoprene-sheathed copper conductor flexible cable, 50ft. (15m) length standard. Type SOOW in North America, EPR in the Middle East and HO7RN in the EU with Trailing cable for thermals and seal probe sensor.

SHAFT SEALS

Double Mechanical Seals, outer and inner are Silicon Carbide, both rotating and stationary faces. Equipped with Moisture Sensor to detect progressive seal wear.

HYDRAULICS

Two Vane Semi-Open Impellers, Hydrodynamically balanced with improved flow pattern contribute to a virtually clog-free pump.

COOLING

Motor casing with large surface area ensure efficient heat dissipation and low temperature rise. Shrink fitted stators and short shaft overhang facilitate cooling.

MATERIALS OF CONSTRUCTION

Pump Casing:	28% Hi-Chrome Iron
Impeller:	28% Hi-Chrome Iron
Suction Cover:	28% Hi-Chrome Iron
Agitator (Optional)	28% Hi-Chrome Iron
Shaft:	403 Stainless Steel
Hardware:	304 Stainless Steel
"O" Rings:	Nitrile Rubber (Viton - Optional)
Mech. Seals:	SC/SC (Upper & Lower)

SURFACE TREATMENT

Primer with Epoxy paint.



Mody Pumps® Inc.

2166 Zeus Court, Bakersfield, CA 93308. USA
Tel.: (661) 392-7600 • Fax: (661) 392-7601
<http://www.modypump.com>
E-mail: sales@modypump.com

mody

MHC SERIES - HI CHROME SLURRY SUBMERSIBLE PUMP

MHC4 SERIES

PORTABLE WET PIT
INSTALLATION

DIMENSIONS CHART (in)				
MODEL	A	B	C **	D *
MHC4/7.5	17	32.6	31.2	9.5
MHC4/10	17	32.3	34.7	9.5

* Lowest Water Level for effective suction
 ** Lowest Water Level for Continuous Operation

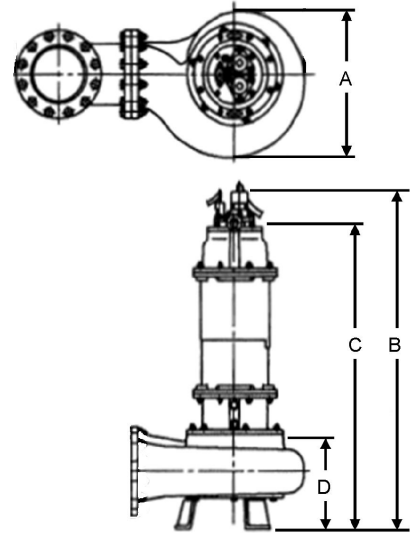

PERFORMANCE CURVES

Performance Curve based
on Clean Water at 68° F with
1.0 SG. Please Correct for
Other Conditions.

Mody MHC Hi-Chrome 4" 7.5HP-10HP

