

mody ELECTRIC SUBMERSIBLE SEWAGE PUMP

MS 6150 SERIES

SUBMERSIBLE SEWAGE PUMPS FOR
STATIONARY WET PIT
INSTALLATION
(P TYPE)
AND
MOBILE WET PIT INSTALLATION
(S TYPE)

.....

Model MS 6150

10" (250mm) Flange ANSI/BSP/DIN
14 HP (10.5kW) @ 60Hz
12 HP (9kW) @ 50 Hz
(High Volume - Low Head)

.....

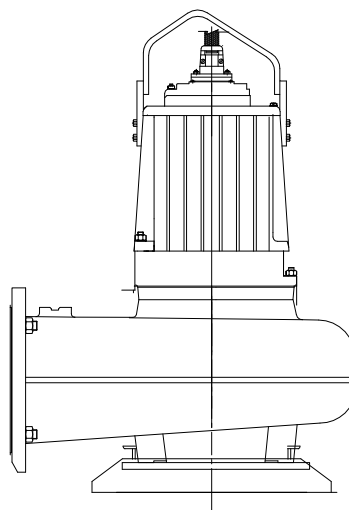

MS-6150

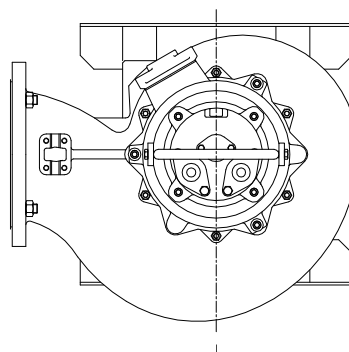

Mody Pumps® Inc.
2166 Zeus Court, Bakersfield, CA 93308. USA
Tel.: (661) 392-7600 • Fax: (661) 392-7601
<http://www.modypump.com>
E-mail: sales@modypump.com

mody

ELECTRIC SUBMERSIBLE SEWAGE PUMP

MS-6150 (9kW) @ 50Hz

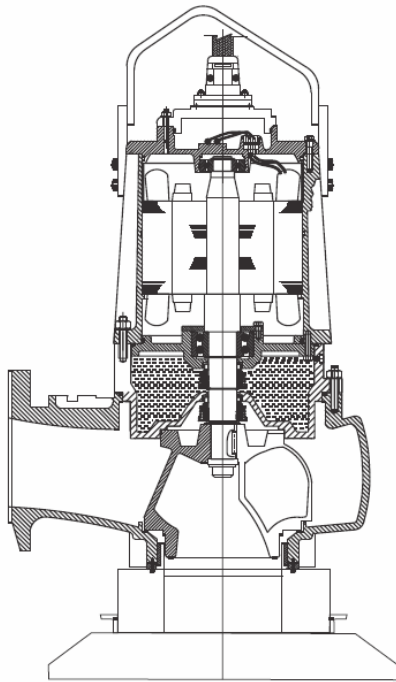

MS-6150 SERIES

MATERIALS OF CONSTRUCTION AND ENGINEERING DATA

MODEL	MS 6150 (50Hz)	MS 6150 (60Hz)
HP/kW	12/9	14/10.5
RPM 60Hz/50Hz	1160/960	1160/960
Max. Amps (FLA @ 460v/400v)	18/21	18/21
Solids Handling: inches/mm	4"/100	4"/100
Weight - P Type (approx.) Lbs./Kg	2000/910	2000/910
Weight - S Type (approx.) Lbs./Kg	1000/455	1000/455
Impeller Type	Channel	Channel
Max. Temperature of Pumped Fluid:	104°F/40°C	104°F/40°C
Max. Starts/Stop Per Hour:	15	15
Max. Submergence:	33'/10m	33'/10m

MOTOR

6-pole induction **continuous rated** motor with squirrel cage rotor. Bi-metallic switches (thermals) embedded in stator winding to protect against overheating. Stator insulation class 'H' (180°C)

POWER SUPPLY

3 phase, 50/60 Hz, AC Supply. Available in any voltage frequency combination. (208/220/230/380/415/460/575/1000V)

BALL BEARINGS

The rotor shaft is carried in two ball bearings. Double row contact lower bearing is capable of carrying high thrust and radial loads. Upper bearing is a deep groove single row oversized bearing. The bearings are enclosed with high temperature grease-containing special Anti-corrosion additive.

POWER CABLE

Waterproof/oil proof, rubber-insulated, neoprene-sheathed copper conductor flexible cable, 50ft. (15m) length standard. Type SOOW in North America, EPR in the Middle East and HO7RN in the EU. (4 core std., 7 core optional)

SHAFT SEALS

Compact Tandem Tungsten Carbide/Tungsten Carbide Upper & Lower Mechanical seals minimize shaft overhang and deflection maximizing mean time between service intervals. Moisture sensor available to detect progressive seal wear.

HYDRAULICS

Single Channel Impellers, Hydrodynamically balanced with improved flow pattern contribute to a virtually clog-free pump.

COOLING

Integral cast cooling fins on motor casing with large surface area ensure efficient heat dissipation and low temperature rise. Shrink fitted stators and short shaft overhang facilitate cooling.

MATERIALS OF CONSTRUCTION

Casing:	Cast Iron ASTM A48 Class 30 (FG 220)
Impeller:	Cast Iron ASTM A48 Class 30 (FG 220)
Shaft:	431 Stainless Steel
Hardware:	304 Stainless Steel
"O" Rings:	Nitrile Rubber
Mech. Seals:	TC/TC (Upper & Lower)

SURFACE TREATMENT

Primer with Epoxy and subsequently coated with black chloric paint for maximum corrosion resistance. pH range 6 - 11.

PERFORMANCE CURVES

