

mody ELECTRIC SUBMERSIBLE SEWAGE PUMP

MODY MSP2 SERIES

SUBMERSIBLE PUMPS:

**DRY PIT
WET PIT
PORTABLE**

MOTORS:

**2-POLE 10 - 19HP
4-POLE 7.5 - 15HP
6-POLE 4.6 - 10HP**

208V-230V-460V-575V/3PH/60HZ

FLOWS to 1,800 US GPM

HEADS to 220 FT TDH

**VORTEX OR CHANNEL
IMPELLERS**



FEATURES

- **HIGH EFFICIENCY MOTORS WITH CLASS H (180°C) INSULATION SYSTEM**
 - EXTENDED SERVICE LIFE CYCLE
 - EXCELLENT FOR VFD APPLICATIONS
- **INTEGRAL "ECO-FRIENDLY" COOLING SYSTEM**
 - NO EXTERNAL COOLING WATER SYSTEM REQUIRED
 - ELIMINATES FOULING FROM PUMPAGE COOLED DESIGNS
 - EXCELLENT FOR CONTINUOUS RUN, DRY PIT APPLICATIONS
- **"FAST - CHANGE" CARTRIDGE MECHANICAL SEALS WITH SILICON CARBIDE SEAL FACES**
 - EXTENDED SERVICE LIFE CYCLE
 - EASY MAINTENANCE IN FIELD
 - NO SPECIAL TOOL REQUIREMENTS
- **ADJUSTABLE WEAR RING SYSTEM**
 - EXTENDED SERVICE LIFE CYCLE
 - EASY MAINTENANCE OF RUNNING CLEARANCES IN THE FIELD
 - NO SPECIAL TOOL REQUIREMENTS
- **VORTEX OR ENCLOSED IMPELLER**
 - IN SAME VOLUTE
 - ON SAME MOTOR SHAFT
 - EASY EXCHANGE IN THE FIELD
 - NO SPECIAL TOOL REQUIREMENTS
- **"FAST - LOCK", QUICK-RELEASE, LATCH-BOLTS**
 - EASY MAINTENANCE IN THE FIELD
 - ELIMINATES NEED FOR VOLUTE HAND HOLE
- **OIL TAP DRAIN**
- **INTERCHANGEABLE PARTS WITH PUMPEX® BRAND MODELS**
- **EASY RETROFIT TO FLYGT® AND MOST OTHER BRAND INSTALLATIONS**



Mody Pumps® Inc.
2166 Zeus Court • Bakersfield, CA 93308 USA
Phone +1 (661) 392.7600 • Fax +1 (661) 392.7601
<http://www.modypump.com> • sales@modypump.com

mody

ELECTRIC SUBMERSIBLE SEWAGE PUMP

MSP SERIES

SPECIFICATIONS

Solid Handling: up to 4"/100mm

Impeller Types: Vortex or channel

Max. Temp. of Pumped Fluid: 104°F/40°C

Max. Starts/Stop Per Hour: 15

Max. Submergence: 66'/20m



MOTOR: NEMA B design, die cast aluminum squirrel cage rotor, induction motor rated for continuous duty with 1.15 service factor. High Efficiency in compliance with “NEMA Energy Efficient Class”. Moisture resistant Class “H” (180°C temperature rating) insulated stator windings, watertight air-filled IP68 enclosure. UL listed components, rated for VFD operation. Siemens design with 2, 4 and 6-pole speed options. Klixon temperature sensors embedded in stator windings for thermal overload protection. Moisture detection probes in main motor cavity, top-end power cable terminal chamber and seal oil reservoir. Optional maintenance free, integral closed loop cooling system available for dry pit or partial submerged continuous duty. Cooling system is separate from pumped liquid. No external cooling source required.

POWER SUPPLY: 208/230/460/575 volts +/-10%, 3-phase, 60-hz AC Supply.

SHAFT: The pump shaft is integral with the motor. The shaft material is AISI 431 stainless steel for corrosion resistance and strength, and conservative in design to accommodate maximum torque requirements at normal start-up condition or any operating point in the system. The shaft has a polished finish with accurately machined shoulders to accommodate bearings, seals and impeller.

BALL BEARINGS: The rotating element is carried by two ball bearings. The lower bearing is a double angular contact ball bearing, C3 with H7 fit, capable of carrying high thrust and radial loads. The upper bearing is a deep groove single row ball bearing, C3 with H7 fit. The bearings are filled with high temperature grease containing special anti-corrosive additive, maintenance free for life. Bearings are conservative in size and properly spaced to transfer all radial and axial loads to the pump housing and minimize shaft deflection. B10 bearing life is greater than 50,000 hours.

POWER CABLE: 33'/10m in length, sized according to IEC, NEC or CSA standards, water/oil resistant EPR insulated, copper conductor flexible cable and additional control cable for moisture sensor and thermals, capable of continuous submerged operation underwater at temperatures to 90°C and to a depth of 66 feet. Additional cable lengths optional.

CABLE ENTRY / JUNCTION CHAMBER SEAL: The cable entry design does not require specific torque requirements to insure a watertight seal. The cable entry consists of a cylindrical elastomer grommet, flanked by stainless steel washers. A cable cap incorporating a strain relief mounts to the cable entry boss compressing the grommet ID to the cable while the grommet OD seals against the bore of the cable entry.

The junction chamber is isolated and sealed from the motor by means of sealing glands and O-rings. Electrical connections between the power cables and motor leads are made via a post type terminal board.

modity ELECTRIC SUBMERSIBLE SEWAGE PUMP

SHAFT SEALS: Cartridge double mechanical shaft seal system to facilitate easy seal changes in the field without special tools. Seal faces are silicon carbide against silicon carbide for long life and resistance to heat and abrasion. Seals operate maintenance free in a reservoir of food grade oil that hydro-dynamically lubricates the seal faces at a constant rate, providing superior heat transfer and maximum cooling. The reservoir is designed to prevent overfilling and to provide lubricant expansion capacity. The oil tap drain has a positive anti-leak seal and is easily accessible from the outside of the pump. The seal system does not rely upon the pumped media for lubrication and will not be damaged when the pump is run dry.

SEAL FAILURE EARLY WARNING SYSTEM: A moisture detection probe is provided in the seal oil chamber for detecting the presence of moisture. A relay device (by others) mounted in the pump control panel or in a separate enclosure sends a low voltage, low amperage signal to the probe. If moisture is present (determined by decreased resistance signals), the relay device energizes a warning light or shutdown circuit in the control panel, protecting the motor from damage.

IMPELLER: Enclosed or vortex, specifically designed for non-clog operation, dynamically balanced and trimmed to meet specified hydraulic operating conditions. The impeller is designed with integral back vanes to prevent solids build-up in the mechanical seal area and to control axial thrust loads on bearings during operation. The impeller slip fits onto the motor shaft with a drive key and is fastened to the shaft by a stainless steel lock screw which is mechanically prevented from loosening by a ratcheting washer assembly that is positively engaged. Channel and vortex impellers are interchangeable with one another in the field without modification to the pump or the need for special tools.

ADJUSTABLE WEAR RING SYSTEM: A replaceable wear ring is securely fitted the pump casing by no less than 3 stainless steel set screws. The wear ring is capable of axial adjustment to reduce hydraulic losses between itself and the enclosed type impeller when wear affects pump efficiency and “Ragging”. This adjustment does not require special tools.

FAST LOCK LATCH BOLTS: The pump includes fast lock / quick release mechanisms with 304 stainless steel latch bolts to allow easy removal of the motor unit from the pump volute without disturbing system piping and the need for special tools. With this feature, a volute hand-hole cover for cleanout access is not required.

LIFTING HANDLE: The pump is supplied with a high quality, high strength stainless steel lifting handle. The handle has a wide opening for easy pump handling and simplified retrieval from any installation.

PUMP VOLUTE: The pump volute is a centerline discharge design, with optional inlet and discharge sizes as specified by technical documentation. Passages are smooth and sized to pass large diameter solids.

MATERIALS OF CONSTRUCTION

Description	Material
Stator Casing:	Cast iron ASTM A-48, Class 35
Pump Volute/Casing:	Cast iron ASTM A-48, Class 35
Casing Wear Ring:	Cast iron ASTM A-48, Class 35
Lifting Handle:	AISI 316 stainless steel
Impeller:	Ductile iron ASTM A-395, Grade 60-40-18
Shaft:	AISI 431 stainless steel
Shaft Sleeve:	AISI 431 stainless steel
Hardware:	AISI 304 stainless steel
Mechanical Seal:	Fast change cartridge, double with silicon carbide vs. silicon carbide faces
O-Rings:	Nitrile rubber

SURFACE TREATMENT: Primer with Epoxy and subsequently coated with black air dry enamel.

mody

ELECTRIC SUBMERSIBLE SEWAGE PUMP

LIMITED WARRANTY

We warrant to our immediate customer and to the ultimate consumer that products of our manufacture will be free of defects in material and workmanship under normal use and service for the following time periods, when installed and maintained in accordance with our instructions.

PUMPS: One (1) year from date of installation or (18) months from date of shipment, whichever occurs first. As used herein, "the ultimate consumer" is defined as the purchaser who first uses the product after it's initial installation or, in the case for product designed for non-permanent installation, the first owner who uses the product. It is the purchaser's or any sub-vendor's obligation to make known to the ultimate consumer the terms and conditions of this warranty. This warranty gives you specific legal rights, and there may also be other rights which vary from state to state. In the event the product is covered by the Federal Consumer Product Warranties Law (1) the duration of any implied warranties associated with the product by virtue of said law is limited to the same duration as stated herein, (2) this warranty is a LIMITED WARRANTY, and (3) no claims of any nature whatsoever shall be made against us, until the ultimate consumer, his successor, or assigns, notifies us in writing of the defect, and delivers the product and/or defective part(s) freight prepaid to our facility or nearest authorized service station. Some states do not allow limitations on how long an implied warranty lasts, so the above limitation may not apply. **THE SOLE AND EXCLUSIVE REMEDY FOR BREACH OF ANY AND ALL WARRANTIES WITH RESPECT TO ANY PRODUCT SHALL BE TO REPLACE OR REPAIR AT OUR ELECTION, FOB POINT OF MANUFACTURE OR AUTHORIZED REPAIR STATION, SUCH PRODUCTS AND/OR PARTS AS PROVEN DEFECTIVE. THERE SHALL BE NO FURTHER LIABILITY, WHETHER BASED ON WARRANTY, NEGLIGENCE OR OTHERWISE.**

Unless expressly stated otherwise, guarantees in the nature of performance specifications furnished in addition to the foregoing material and workmanship warranties on a product manufactured by *Mody*, if any, are subject to laboratory tests corrected for field performance. Any additional guarantees, in the nature of performance specifications must be in writing and such writing must be signed by our authorized representative. Due to inaccuracies in field testing if a conflict arises between the results of field testing conducted by or for user, and laboratory tests corrected for field performance, the latter shall control. Components or accessories supplied by us but manufactured by others are warranted only to the extent of and by the terms and conditions of the original manufacturer's warranty.

RECOMMENDATIONS FOR SPECIAL APPLICATIONS OR THOSE RESULTING FROM SYSTEMS ANALYSES AND EVALUATIONS WE CONDUCT, WILL BE BASED ON OUR BEST AVAILABLE EXPERIENCE AND PUBLISHED INDUSTRY INFORMATION. SUCH RECOMMENDATIONS DO NOT CONSTITUTE A WARRANTY OF SATISFACTORY PERFORMANCE AND NO SUCH WARRANTY IS GIVEN.

This warranty shall not apply when damage is caused by (a) improper installation, (b) improper voltage, (c) lightning, (d) sand or other abrasive materials, (e) scale or corrosion build-up due to excessive chemical content. Any modification of the equipment will also void the warranty. We will not be responsible for loss, damage or labor cost due to interruption of service caused by defective parts. Neither will we accept charges incurred by others without our prior written approval. This warranty is void if our inspection reveals the product was used in a manner inconsistent with normal industry practice and/or our specific recommendations. The purchaser is responsible for communication of all necessary information regarding the application and use of the product. **UNDER NO CIRCUMSTANCES WILL WE BE RESPONSIBLE FOR ANY OTHER DIRECT OR CONSEQUENTIAL DAMAGES, INCLUDING BUT NOT LIMITED TO LOST PROFITS, LOST INCOME, LABOR CHARGES, DELAYS IN PRODUCTION, IDLE PRODUCTION, WHICH DAMAGES ARE CAUSED BY ANY DEFECTS IN MATERIAL, AND/OR WORKMANSHIP AND/OR DELAYS IN SHIPMENT. THIS WARRANTY IS EXPRESSLY IN LIEU OF ANY OTHER EXPRESS OR IMPLIED WARRANTY, INCLUDING ANY WARRANTY OF MERCHANTABILITY OR FITNESS FOR A PARTICULAR PURPOSE.** No rights extended under this warranty shall be assigned to any person, whether by operation or otherwise, without our prior written approval.

MODY PUMPS, INC
2166 Zeus Court, Bakersfield, CA 93308 USA
Phone: +1 (661) 392.7600 • Fax: +1 (661) 392.7601

mody ELECTRIC SUBMERSIBLE SEWAGE PUMP

MSP2-80.0-4 VORTEX 1 1740 RPM

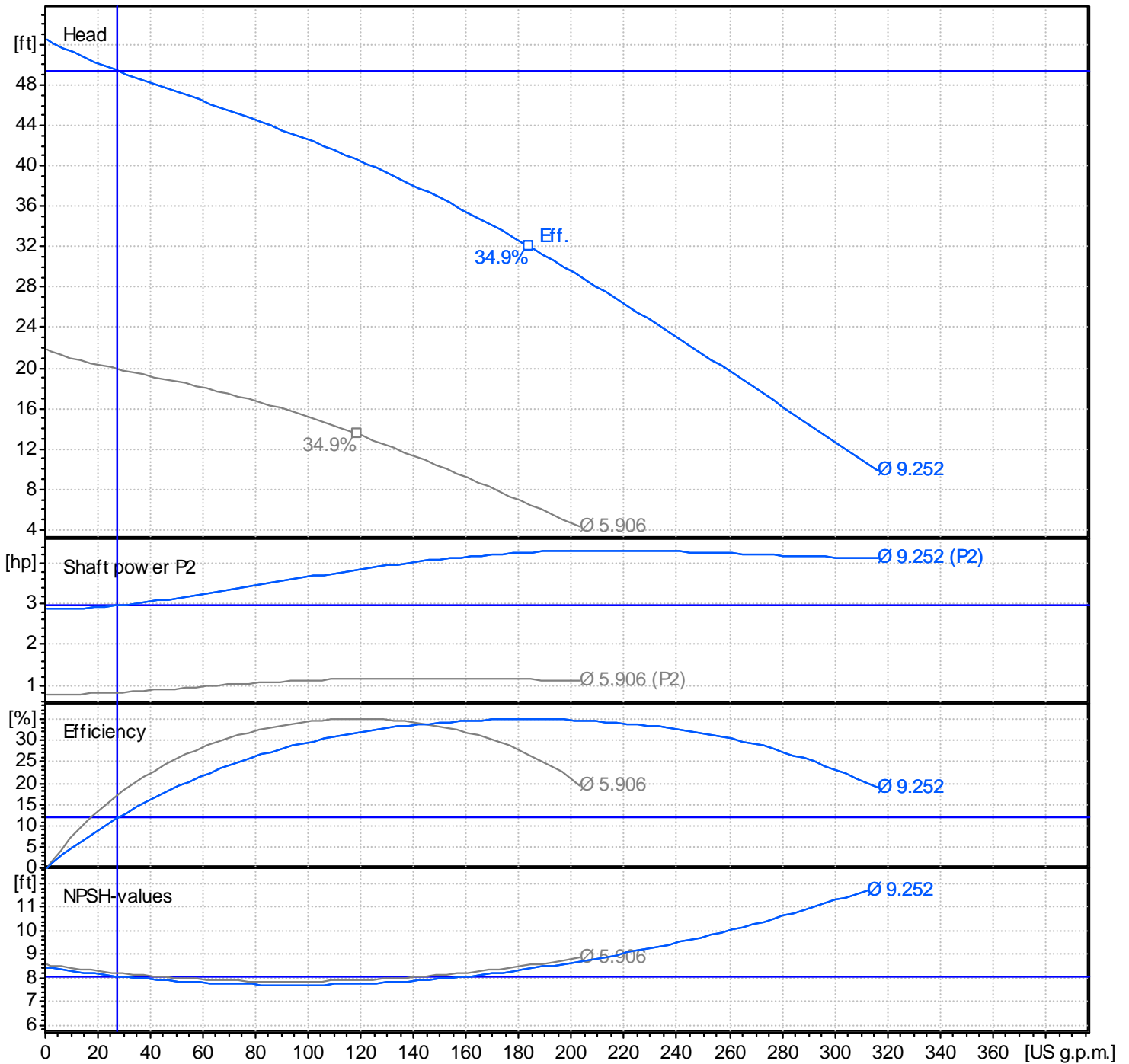

mody ELECTRIC SUBMERSIBLE SEWAGE PUMP

MSP2-80.0-2 VORTEX 1 3500 RPM

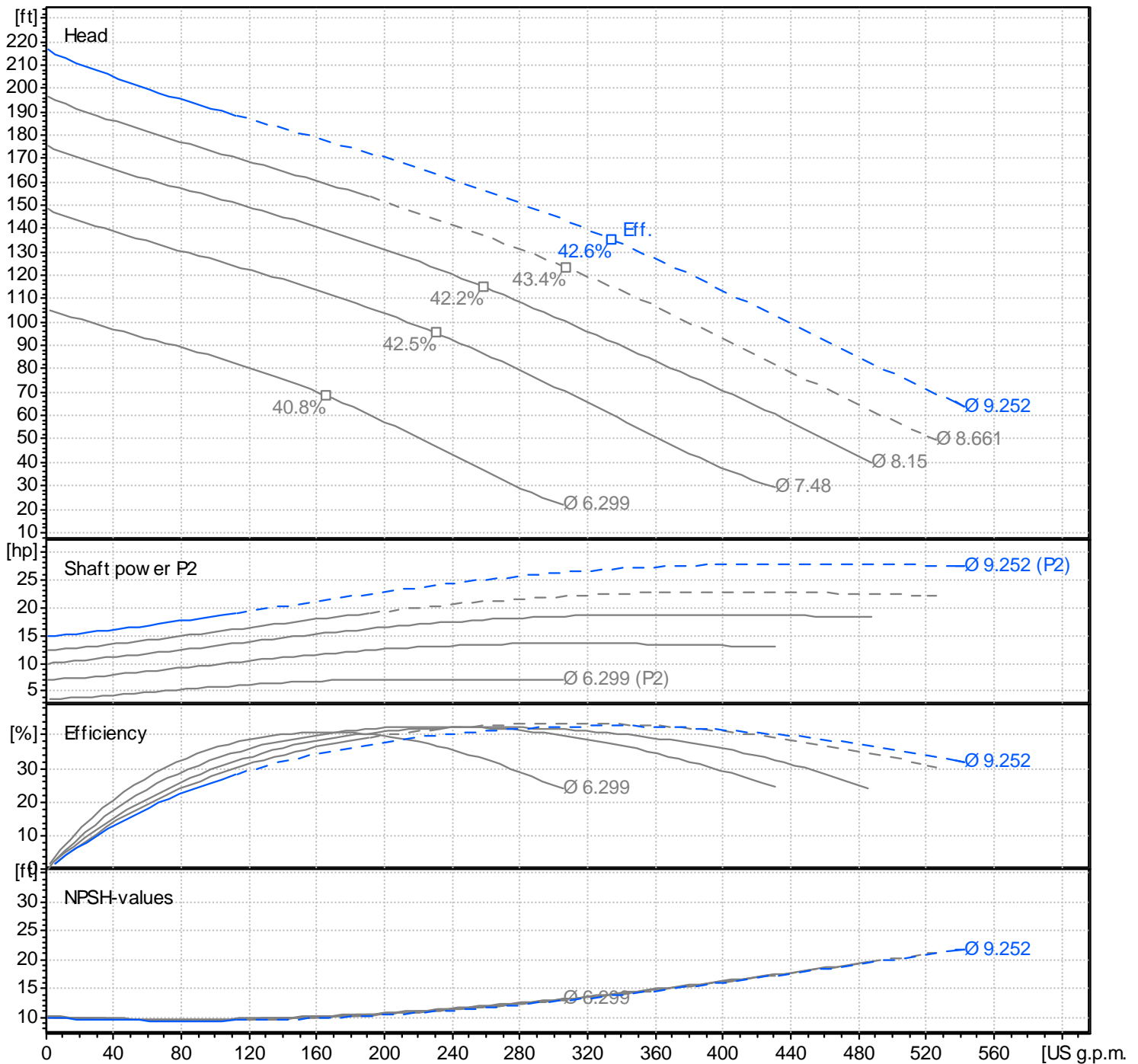

mody ELECTRIC SUBMERSIBLE SEWAGE PUMP

MSP2-100.0-4 Channel 1 1740 RPM

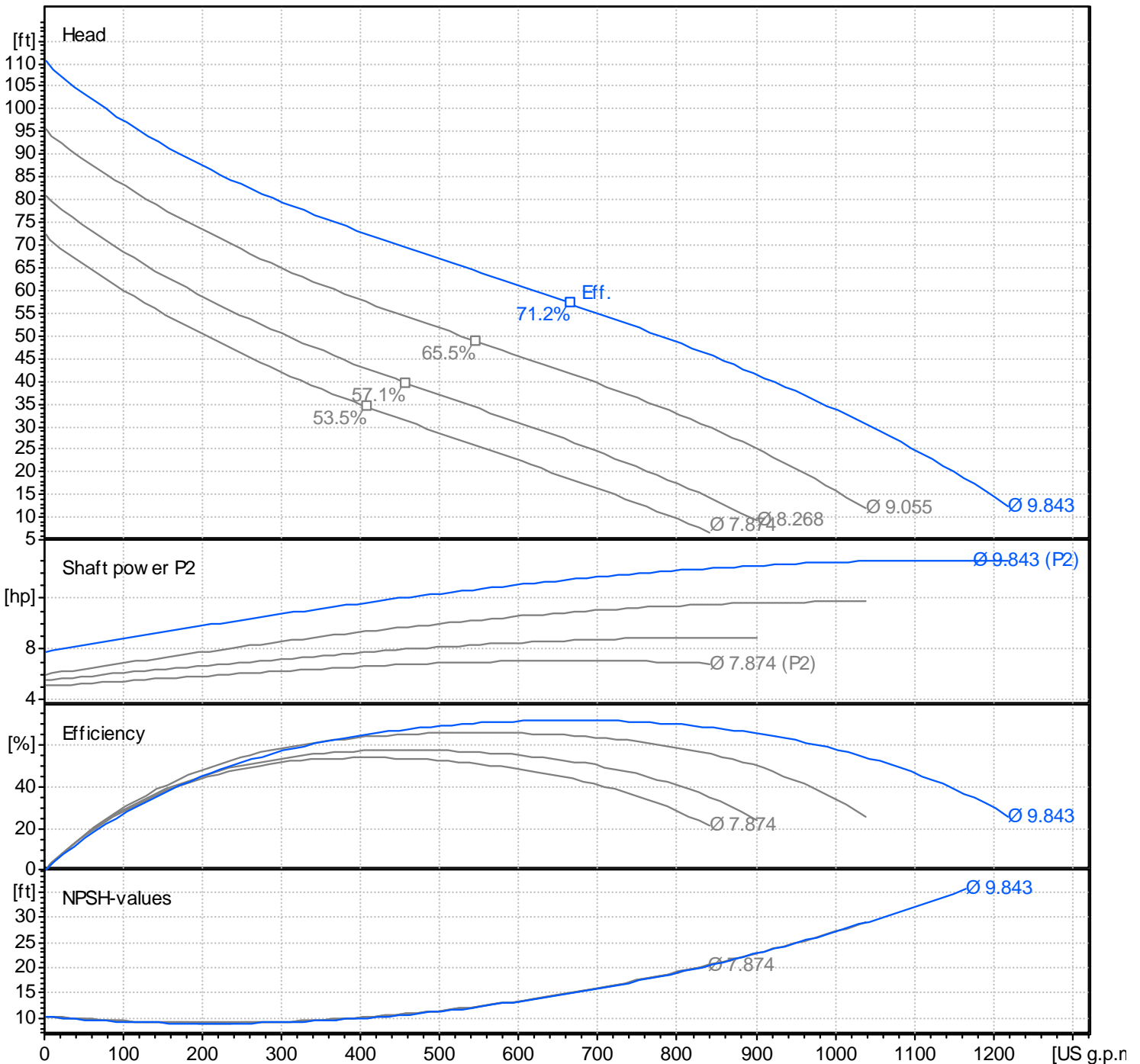

mody ELECTRIC SUBMERSIBLE SEWAGE PUMP

MSP2-100.0-4 Vortex 1 1740 RPM

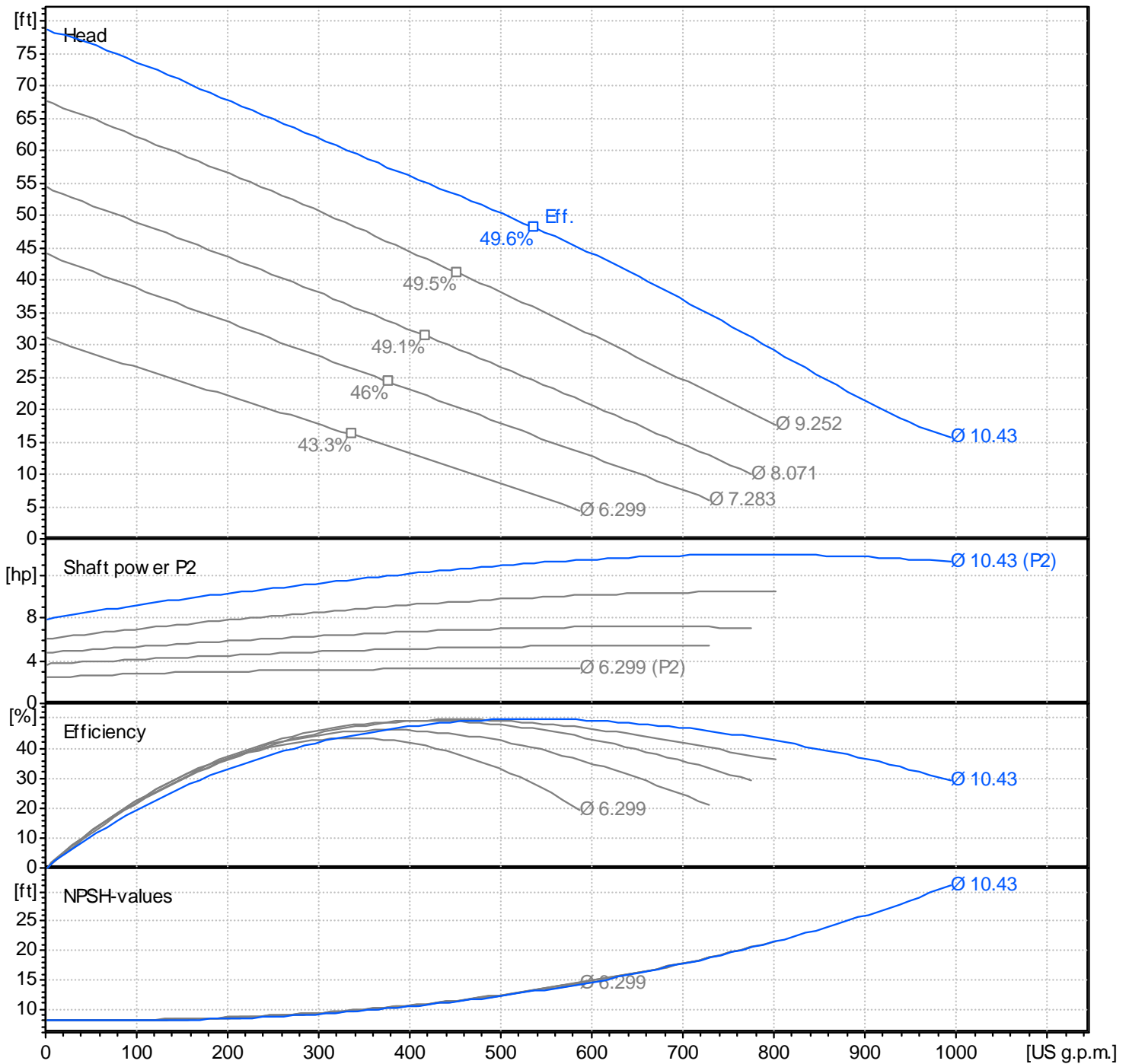

mody ELECTRIC SUBMERSIBLE SEWAGE PUMP

MSP2-100.0-4 Vortex 2 1740 RPM

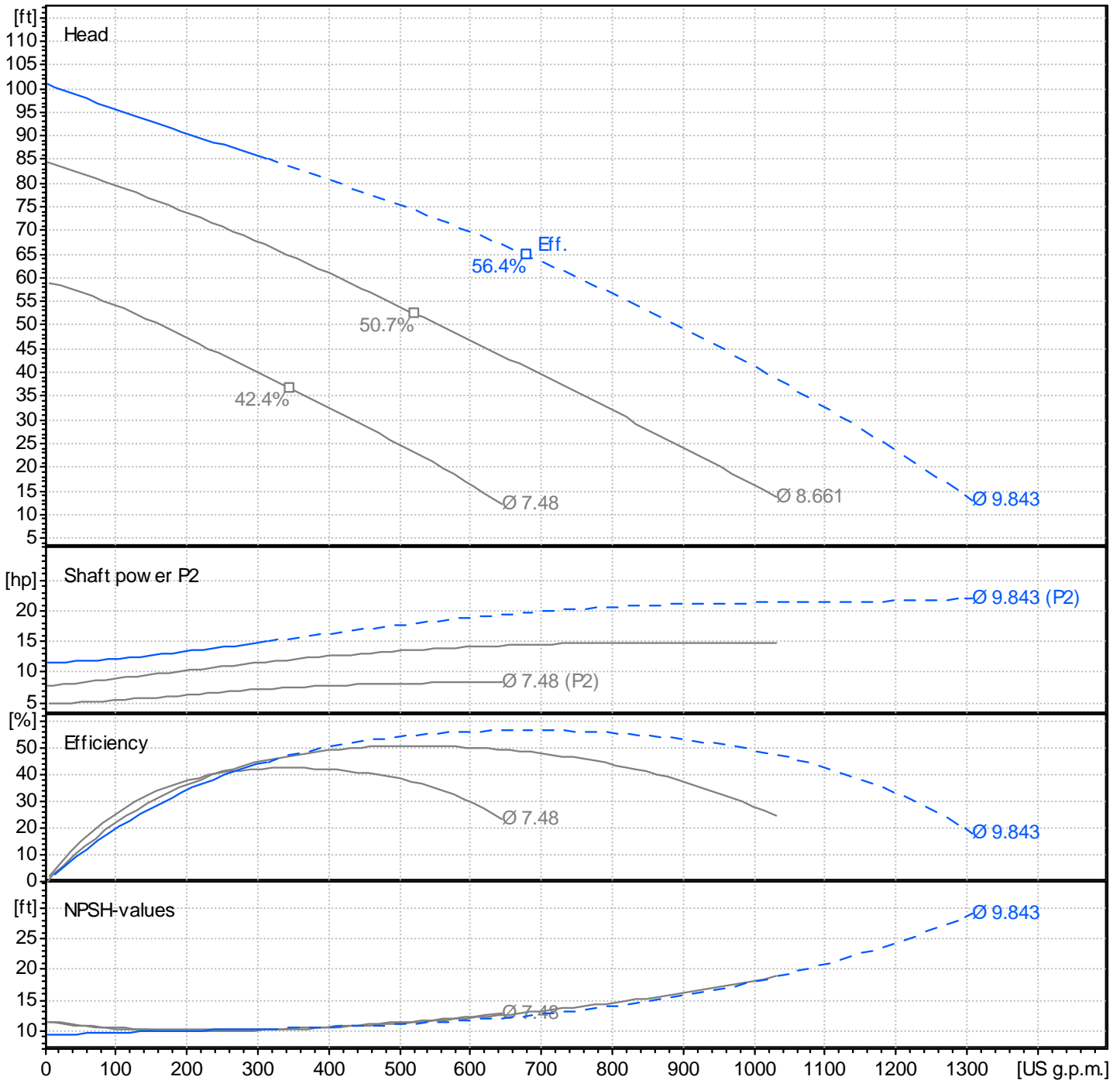

mody ELECTRIC SUBMERSIBLE SEWAGE PUMP

MSP2-100.0-6 Channel 1 1140 RPM

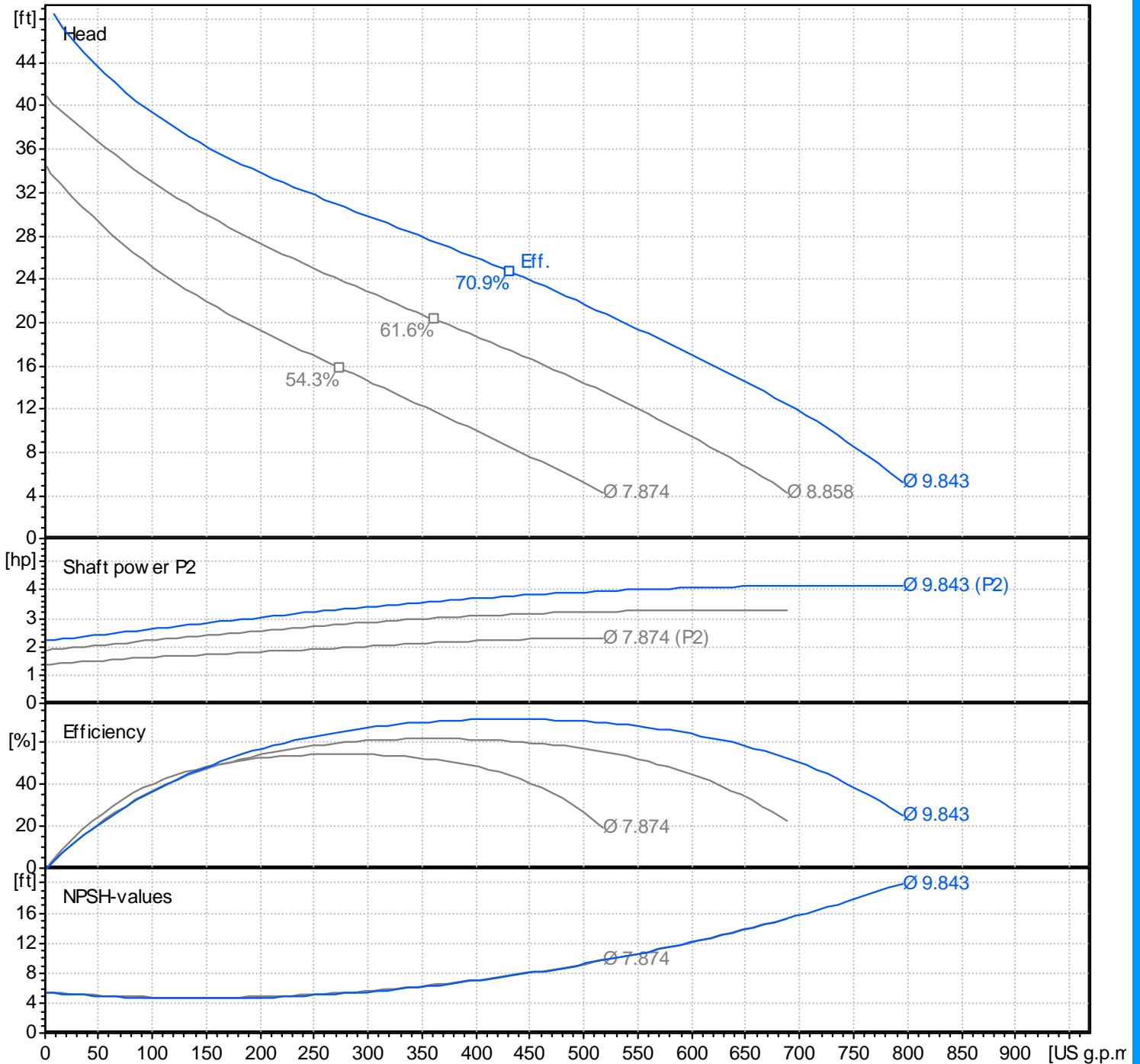

mody ELECTRIC SUBMERSIBLE SEWAGE PUMP

MSP2-100.0-6 Vortex 1 1140 RPM

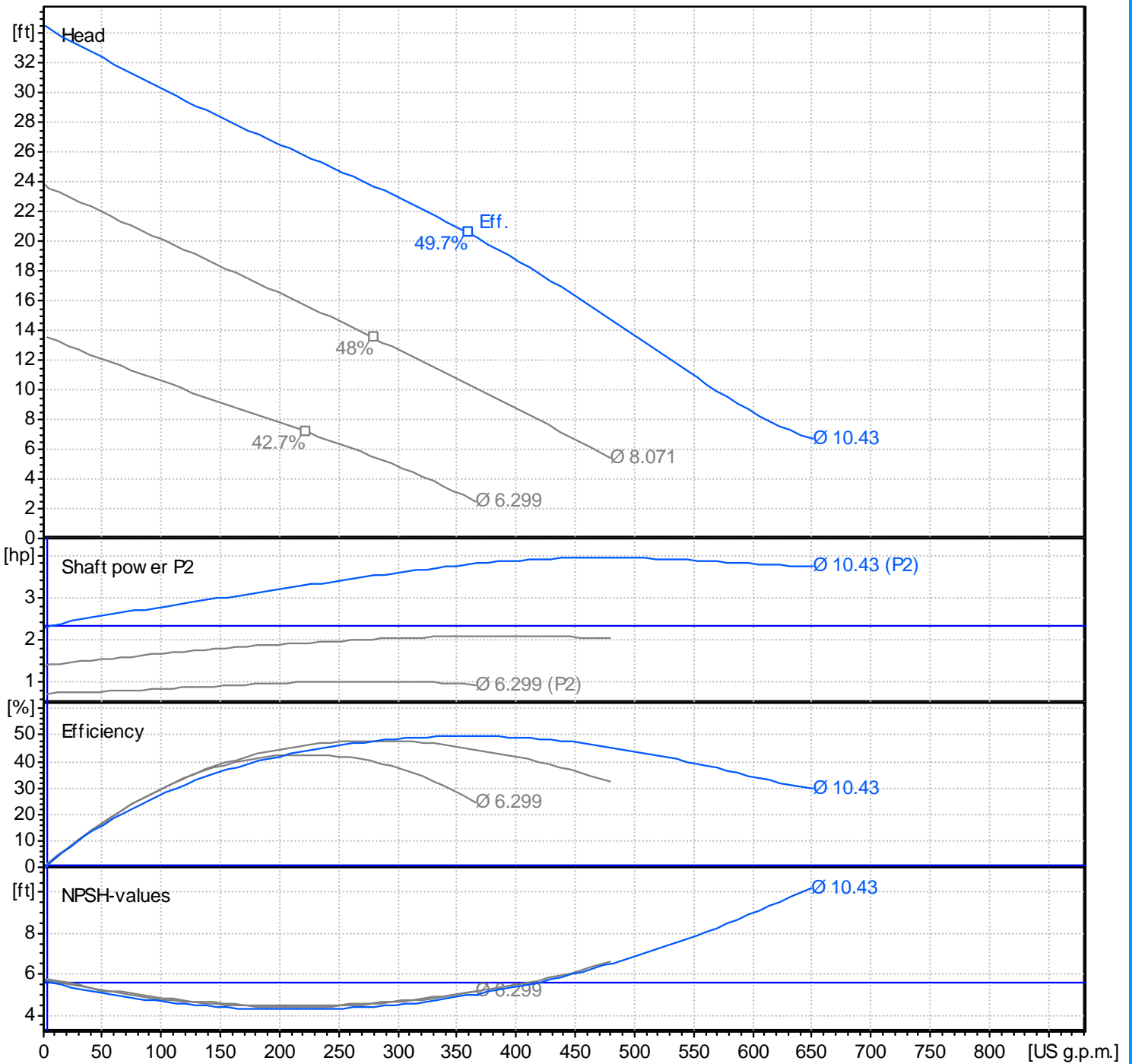

mody ELECTRIC SUBMERSIBLE SEWAGE PUMP

MSP2-100.0-6 Vortex 2 1140 RPM

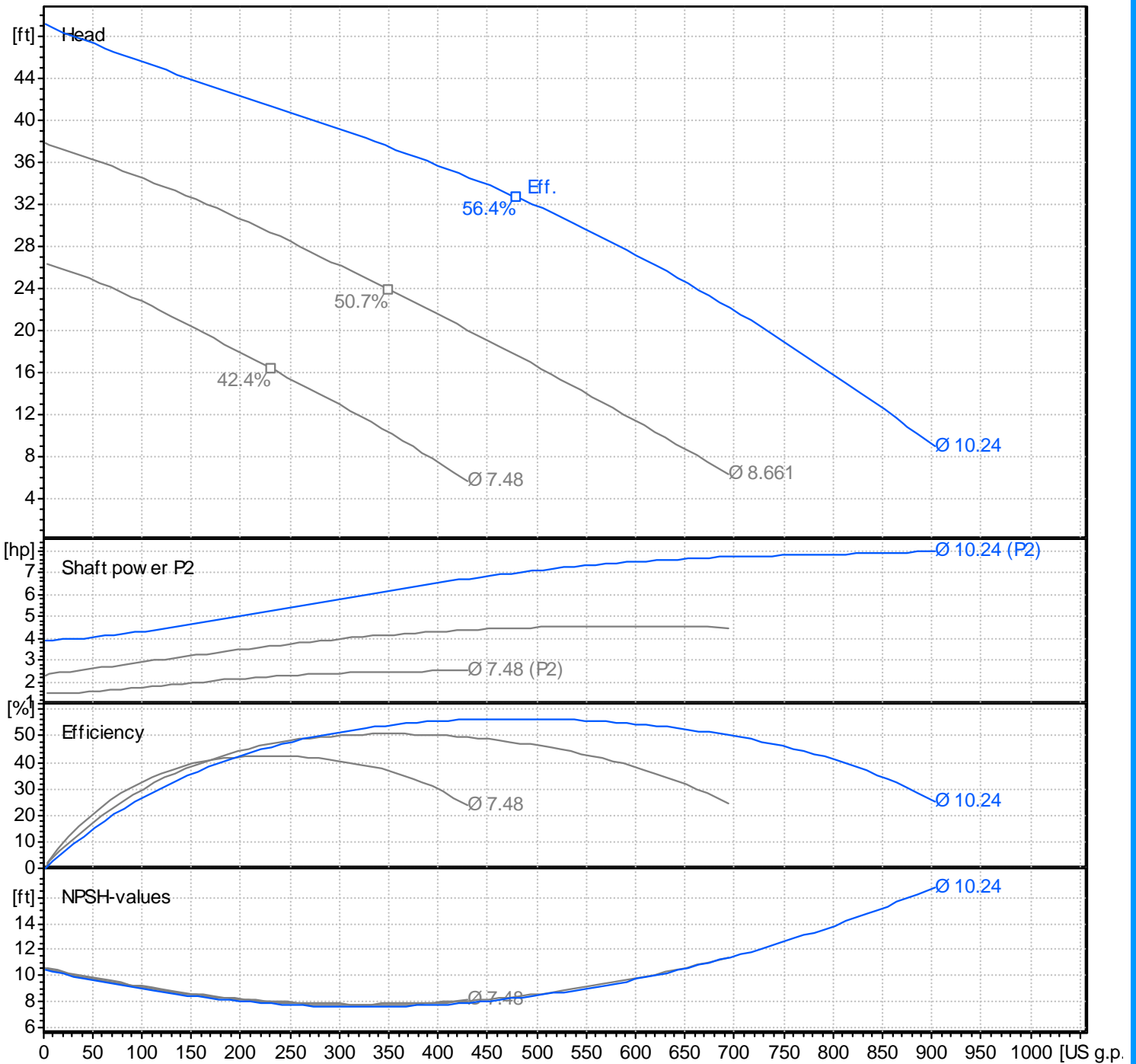

mody ELECTRIC SUBMERSIBLE SEWAGE PUMP

MSP2-150.1-4 Channel 1 1740 RPM

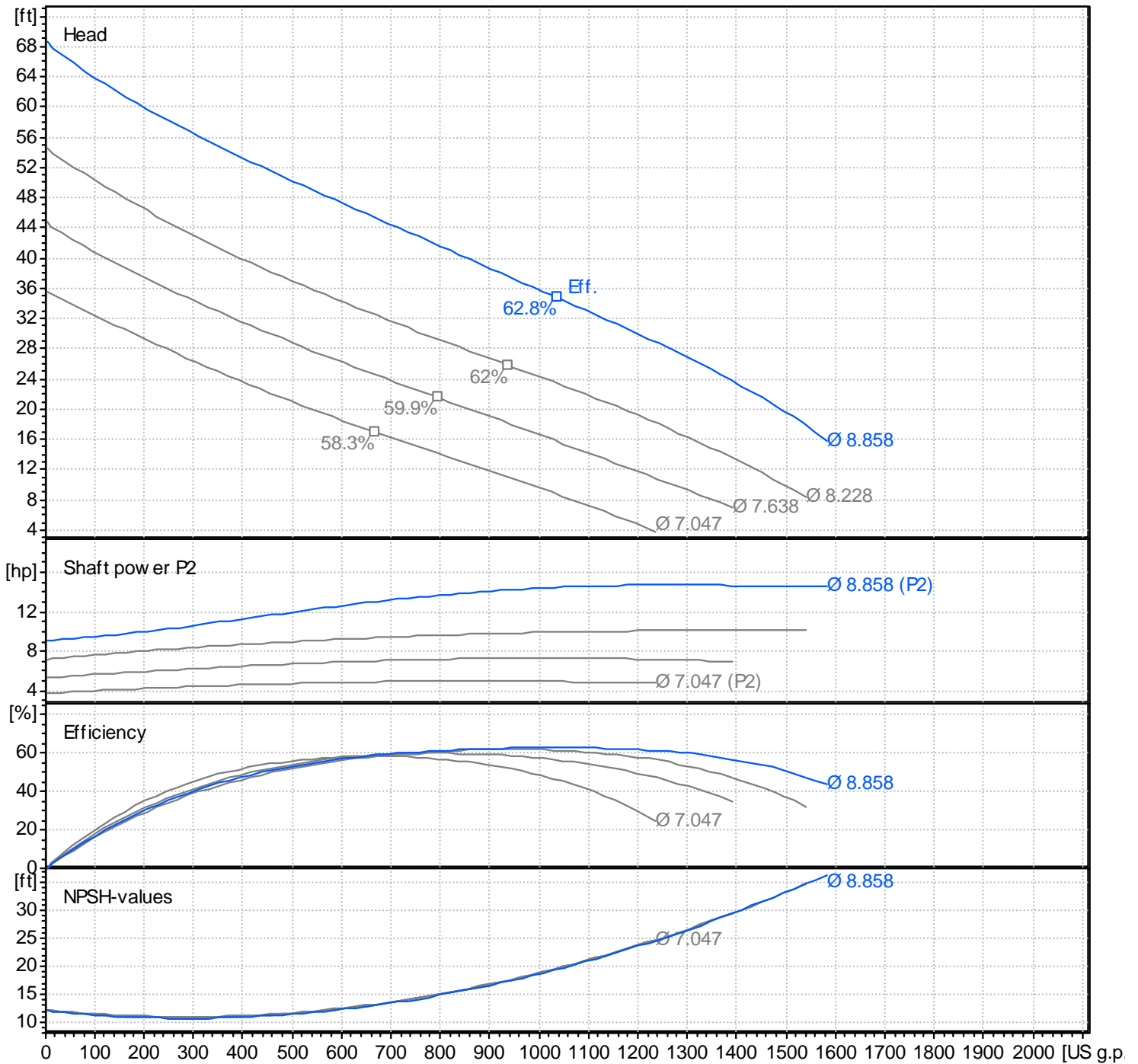

mody ELECTRIC SUBMERSIBLE SEWAGE PUMP

MSP2-150.1-4 Vortex 1 1740 RPM

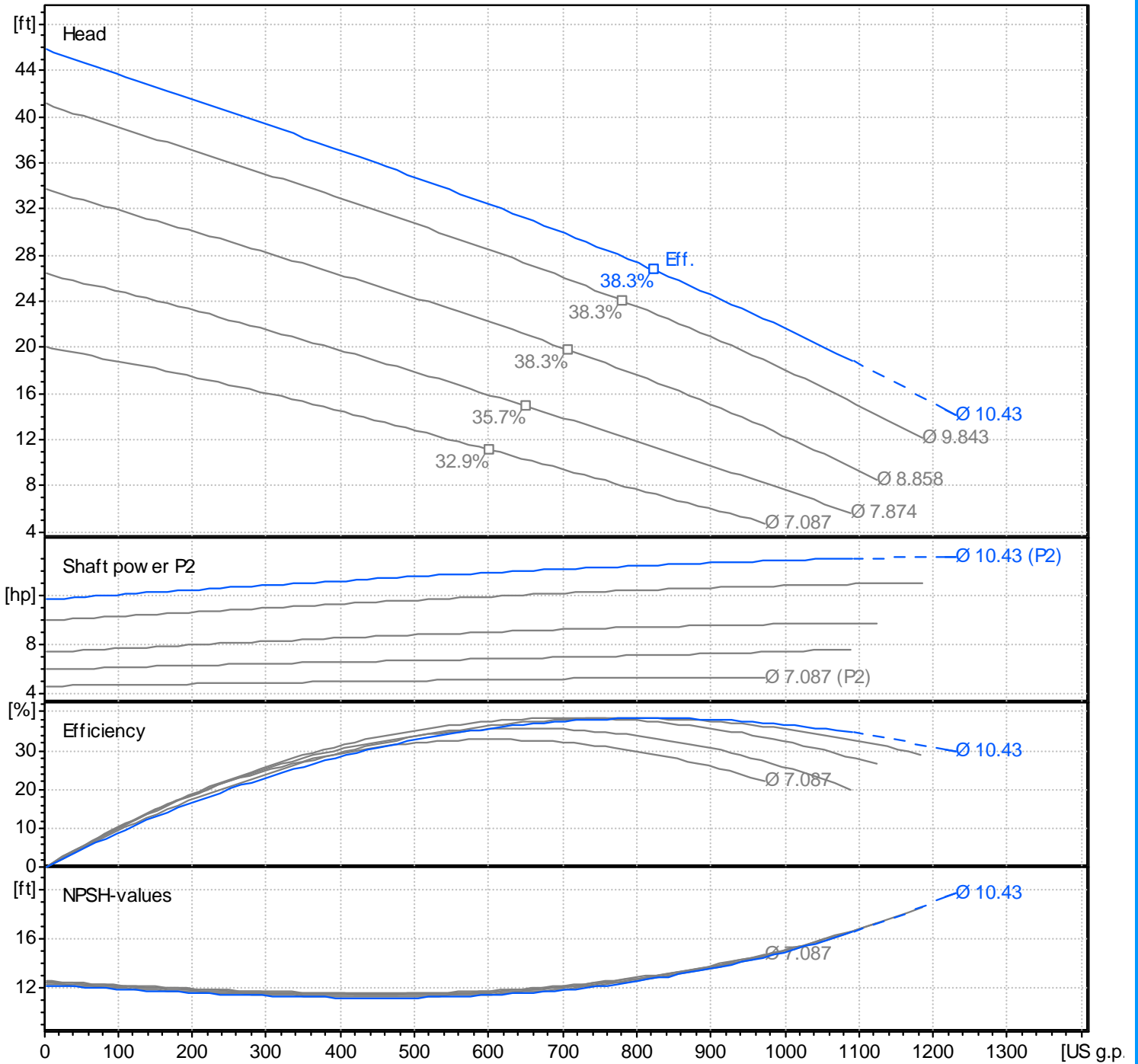

mody ELECTRIC SUBMERSIBLE SEWAGE PUMP

MSP2-150.0-4 Vortex 2 1740 RPM

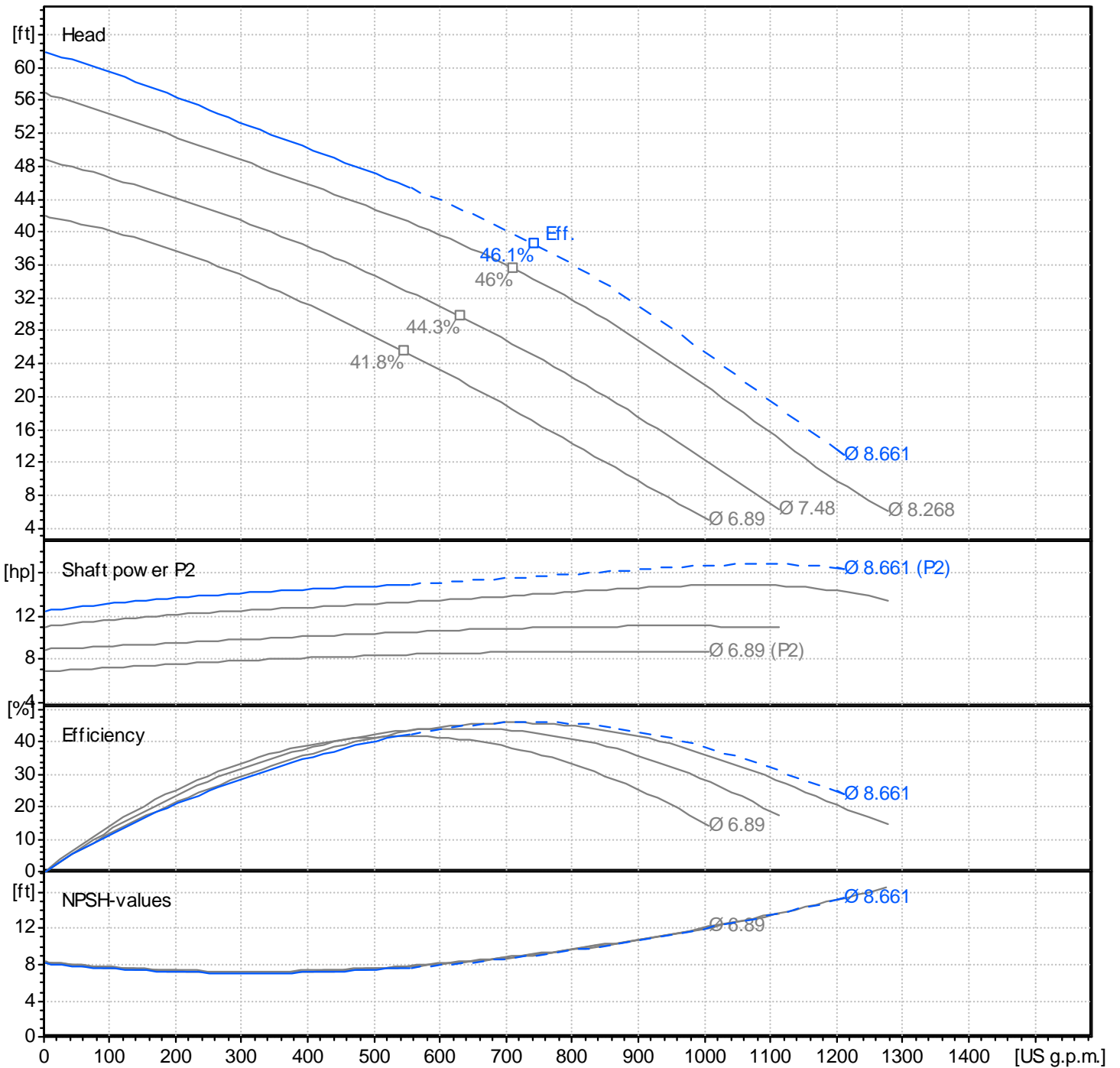

mody ELECTRIC SUBMERSIBLE SEWAGE PUMP

MSP2-150.0-6 Vortex 2 1140 RPM

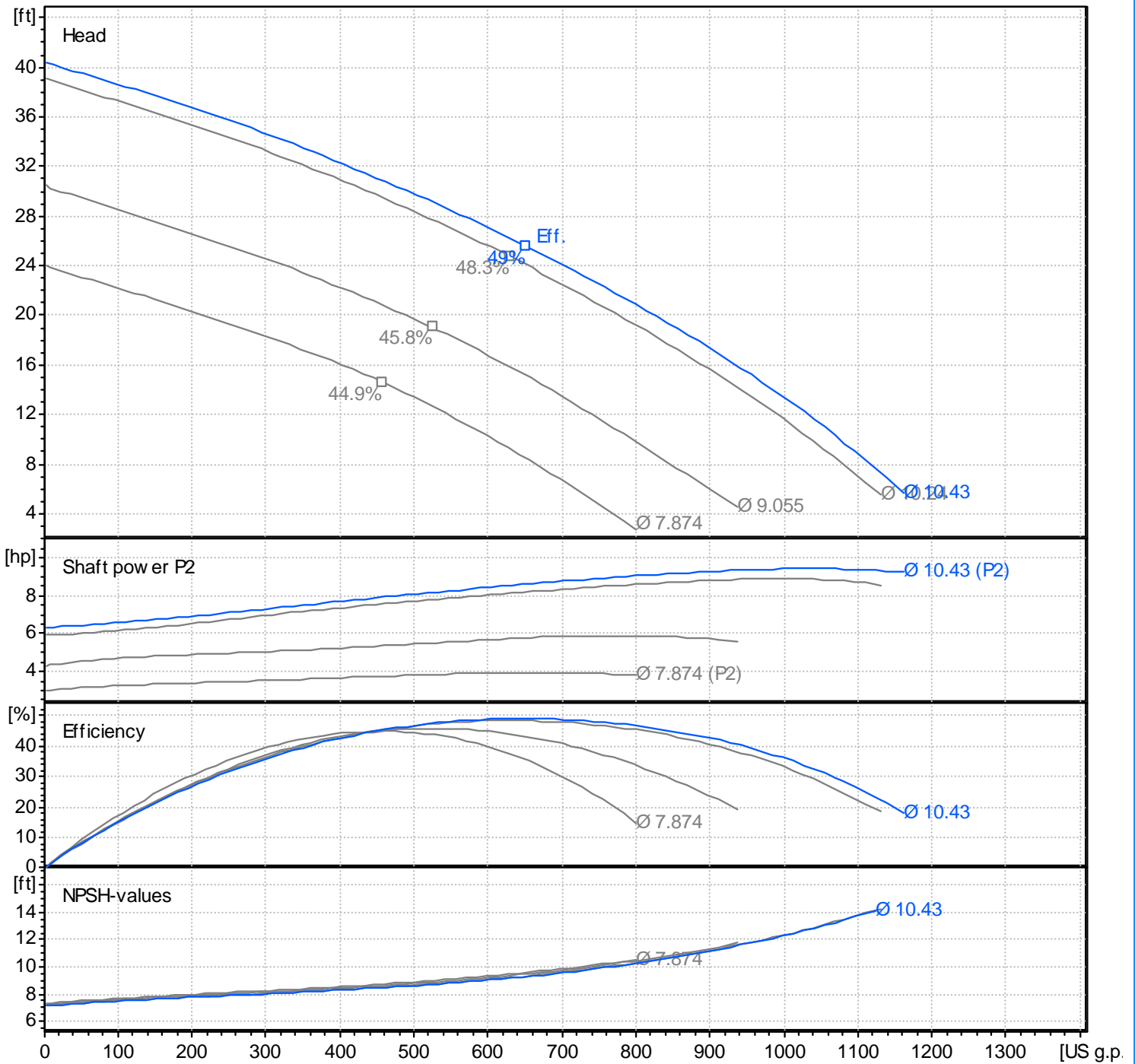

mody

ELECTRIC SUBMERSIBLE SEWAGE PUMP

MSP2-SERIES WET PIT INSTALLATION

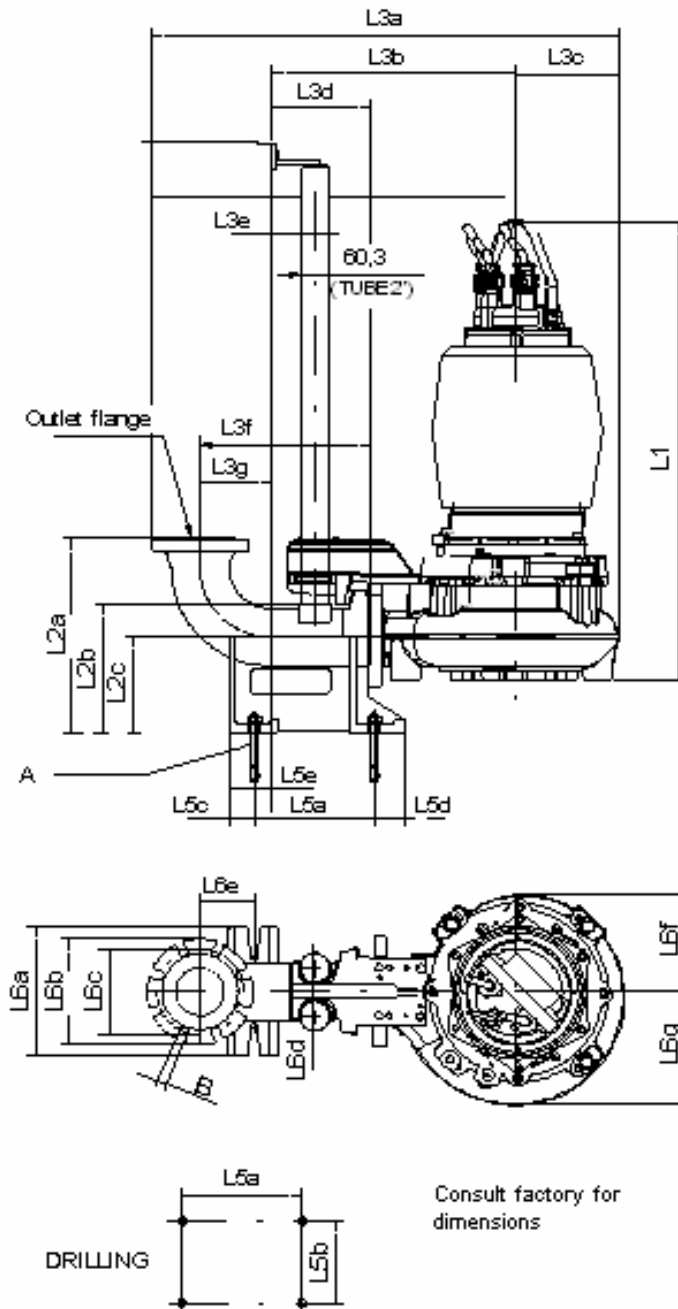

mody

ELECTRIC SUBMERSIBLE SEWAGE PUMP

MSP2-SERIES DRY PIT INSTALLATION

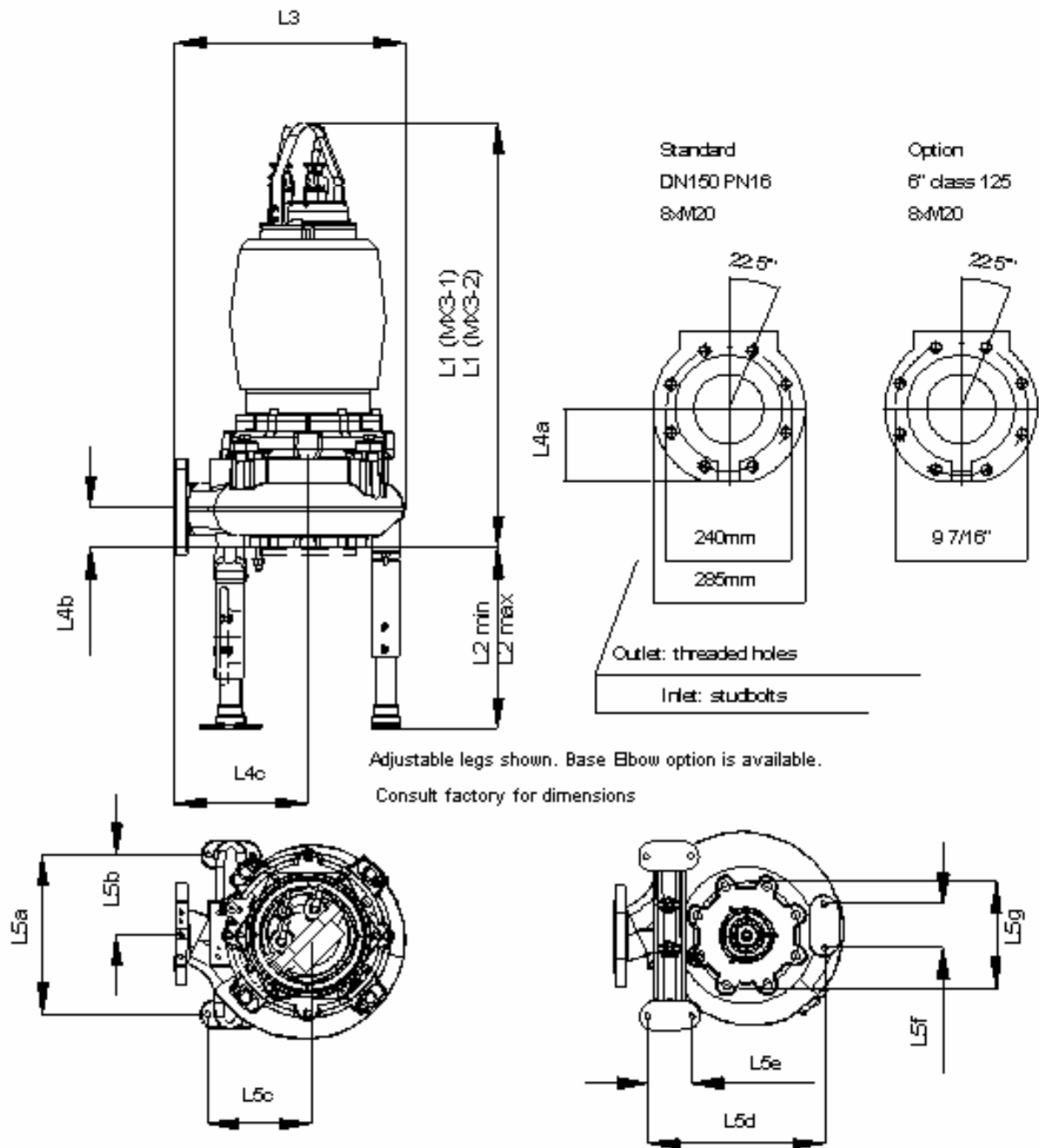

mody

ELECTRIC SUBMERSIBLE SEWAGE PUMP

MSP2-SERIES PORTABLE INSTALLATION

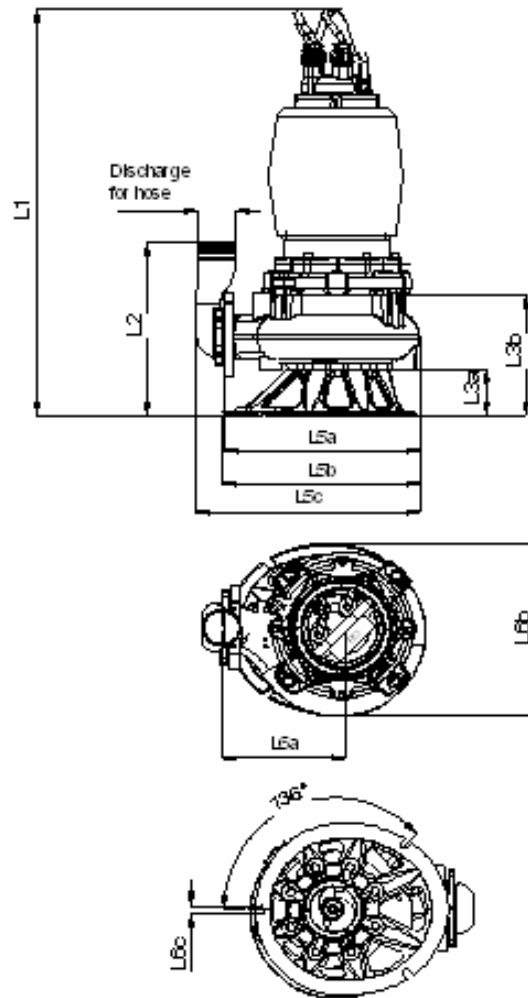

Consult factory for dimensions

mody

ELECTRIC SUBMERSIBLE SEWAGE PUMP

MSP2-SERIES PARTS SCHEMATIC

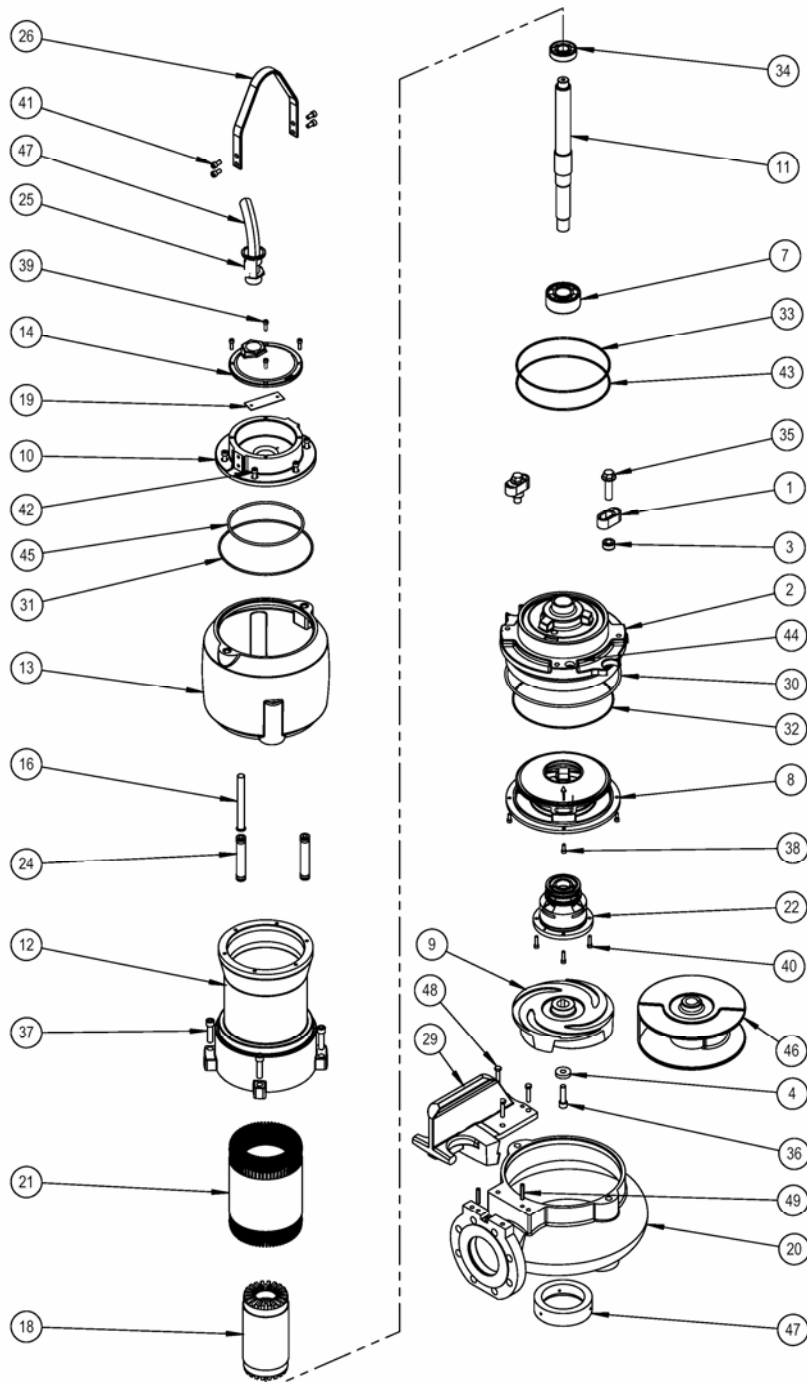

mody

ELECTRIC SUBMERSIBLE SEWAGE PUMP

MSP2-SERIES PARTS LIST

ITEM NO.	PART DESCRIPTION	QTY	MATERIAL
1	LATCH BOLT (FAST LOCK) (SMALL)	2	AISI 304 STAINLESS STEEL
2	LOWER BEARING HOUSING	1	ASTM A48 CLASS 35 CAST IRON
3	WASHER SPACER	2	TEFLON
4	IMPELLER WASHER	1	AISI 304 STAINLESS STEEL
7	BEARING LOWER	1	3307B.2ZTNG
8	COOLING FLANGE LOWER	1	ASTM A48 CLASS 35 CAST IRON
9	IMPELLER VORTEX VX2-80	1	ASTM A395 DUCTILE IRON, GRADE 60-40-18
	IMPELLER VORTEX VX2-100		ASTM A395 DUCTILE IRON, GRADE 60-40-18
	IMPELLER VORTEX VXX2-100/150		ASTM A395 DUCTILE IRON, GRADE 60-40-18
10	UPPER BEARING HOUSING	1	ASTM A48 CLASS 35 CAST IRON
11	SHAFT FOR 170 STATOR	1	AISI 304 STAINLESS STEEL
12	STATOR HOUSING PX2-1	1	ASTM A48 CLASS 35 CAST IRON
12a	STATOR HOUSING PX2-2	1	ASTM A48 CLASS 35 CAST IRON
13	COOLING JACKET	1	ASTM A48 CLASS 35 CAST IRON
14	MOTOR COVER	1	ASTM A48 CLASS 35 CAST IRON
16	COOLING TUBE	1	RUBBER / STAINLESS STEEL
18	SHAFT ROTOR	1	SIEMENS
19	NAME PLATE	1	AISI 304 STAINLESS STEEL
20	VOLUTE-100	1	ASTM A48 CLASS 35 CAST IRON
20a	VOLUTE-150	1	ASTM A48 CLASS 35 CAST IRON
20b	VOLUTE-80	1	ASTM A48 CLASS 35 CAST IRON
21	WIRE CORE	1	SIEMENS
22	SEAL CATRIDGE ASSEMBLY	1	
24	COOLANT HOSE ASSEMBLY	2	RUBBER / STAINLESS STEEL
25	CABLE SEAL compl.	1	
26	HANDLE	1	AISI 304 STAINLESS STEEL
29	ADAPTER	1	ASTM A395 DUCTILE IRON, GRADE 60-40-18
30	O-RINGS	1	NITRILE RUBBER
31	O-RINGS	1	NITRILE RUBBER
32	O-RINGS	1	NITRILE RUBBER
33	O-RINGS	1	NITRILE RUBBER
34	BEARING UPPER	1	6305DDU C3
35	BOLT	2	AISI 304 STAINLESS STEEL
36	BOLT	1	AISI 304 STAINLESS STEEL
37	BOLT	4	AISI 304 STAINLESS STEEL
38	BOLT	4	AISI 304 STAINLESS STEEL
39	BOLT	4	AISI 304 STAINLESS STEEL
40	BOLT	4	AISI 304 STAINLESS STEEL
41	BOLT	4	AISI 304 STAINLESS STEEL
42	BOLT	6	AISI 304 STAINLESS STEEL
43	O-RINGS	1	NITRILE RUBBER
44	O-RINGS	1	NITRILE RUBBER
45	O-RINGS	1	NITRILE RUBBER
46	CHANNEL IMPELLER-100 CX2-100	1	ASTM A395 DUCTILE IRON, GRADE 60-40-18
46b	CHANNEL IMPELLER-150 CX2-150		ASTM A395 DUCTILE IRON, GRADE 60-40-18
47	WEAR RING PX2-100	1	ASTM A48 CLASS 35 CAST IRON
	WEAR RING PX2-150	1	ASTM A48 CLASS 35 CAST IRON
48	BOLT	4	AISI 304 STAINLESS STEEL
49	GUIDE PIN	2	STEEL
	O-RING KIT	1	NITRILE RUBBER