

mody ELECTRIC SUBMERSIBLE NON-CLOG SLUDGE PUMP

NC SERIES

**PORTABLE ELECTRIC
SUBMERSIBLE SLUDGE PUMP
FOR
CORROSIVE & ABRASIVE
APPLICATIONS**

.....
6 HP (4.5kW)

NC 06

4" (100mm) Flange or Hose
.....

8 HP (6kW)

NC 08

4" (100mm) Flange or Hose
.....

10 HP (7.5kW)

NC 10

4" (100mm) Flange or Hose
.....



NON-CLOG SLUDGE SERIES DESIGN ADVANTAGES

- Stainless Steel Volute, Shaft, Impeller, Outlet and Hardware for maximum corrosion resistance.
- Choice of impeller materials:
 - 1) 316 Stainless Steel for sea water and corrosive applications and;
 - 2) Nitride Hardened 410 Stainless Steel for abrasive applications. (Standard)
- Tandem Tungsten Carbide/Tungsten Carbide and Tungsten Carbide/Tungsten Carbide mechanical seals.
- Mechanical Seals in wholly enclosed pressure compensated oil chamber.
- Built-in Automatic ON/OFF/ON thermal overload switches protect the motor. Thermal Protectors wired directly to built-in contactor for maximum reliability.
- Equipped with moisture sensor that detects progressive seal wear and automatically shuts down the pump.
- Replaceable Nitrile Rubber-lined Wear Plate Optimizes efficiency throughout the life of the pump.
- Equipped with Sacrificial Zinc Anodes for maximum life in a saline fluid environment.



Mody Pumps® Inc.
2166 Zeus Court, Bakersfield, CA 93308. USA
Tel.: (661) 392-7600 • Fax: (661) 392-7601
<http://www.modypump.com>
E-mail: sales@modypump.com

mody

ELECTRIC SUBMERSIBLE NON-CLOG SLUDGE PUMP

NON-CLOG SLUDGE SERIES 6HP(4.5kW) / 8HP(6kW) / 10HP(7.5kW)

Model	A
NC-06360M	29.5"
NC-08360M	31.0"
NC-10360M	31.5"

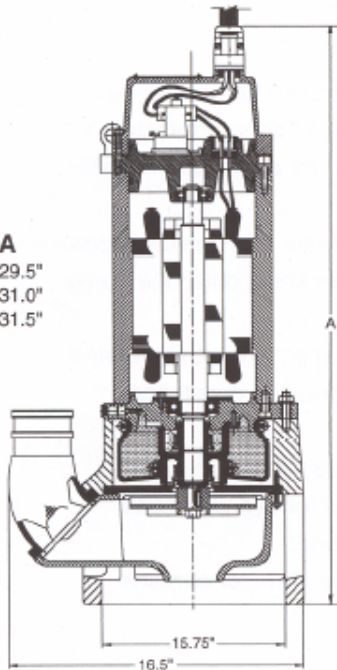

Max. Sphere Size 2.5"/65mm

PERFORMANCE CURVES

MODEL: NC 06M/08M/10M (50/60 Hz)

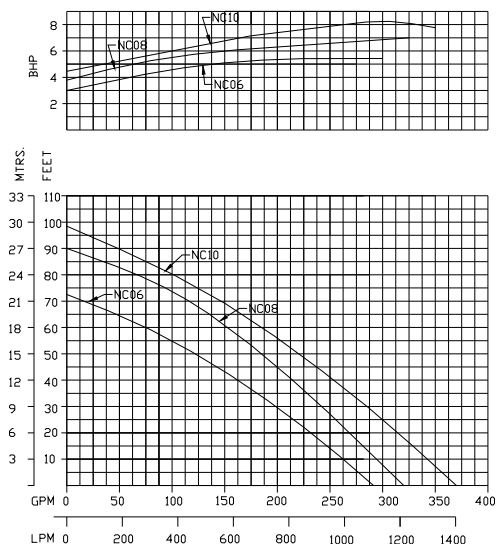

NON-CLOG SERIES

MATERIALS OF CONSTRUCTION AND ENGINEERING DATA

MOTOR

2-pole induction **continuous rated** motor with squirrel cage rotor.
Stator insulation class 'H' (180°C)
Speed : 3400 RPM @ 60 Hz, 2800 RPM @ 50 Hz
Power Rating : 6/8/10HP @ 60 Hz, 4.5/6/7.5kW @ 50Hz Full Load
Current FLA: 9.8, 12, 14 Amps @ 460v. 11, 13.8, 16 Amps @ 400v.
Max. temperature of the pump liquid : 104°F/40°C
Max. start/stop per hour : 15

POWER SUPPLY

3 phase, 50/60 Hz, AC Supply. Available in any voltage frequency combination. (208/220/230/380/415/460/575/1000V) Moisture sensor available in 200/400v configurations only. Built in Contactor which trips at excessively high motor temperatures through bimetallic switches in the winding.

BALL BEARINGS

The rotor shaft is carried in two single row, deep groove ball bearings. The bearings are enclosed with high temperature grease-containing special Anti-corrosion additive.

POWER CABLE

Waterproof/oil proof, rubber-insulated, neoprene-sheathed copper conductor flexible cable, 50ft. (15m) length standard. Type SOOW in North America, EPR in the Middle East and HO7RN in the EU.

SHAFT SEAL

Tandem Tungsten Carbide/Tungsten Carbide and Tungsten Carbide/Tungsten Carbide Mechanical seals wholly enclosed in a pressure compensated oil chamber.

CORROSION RESISTANT

Epoxy coated Extruded Aluminum Stator Casing
Nitrile Rubber- Lined Wear plate.
Shaft: 431 Stainless Steel
Hardware: 304 Stainless Steel
Impeller: Nitride Hardened 410SS to 56HRC is Standard.
Volute: 304 Stainless Steel
pH Range 5 - 8

SUBMERGENCE

Submergence below liquid surface min 8" (127mm) max. 50' (15m).

WEIGHTS (Approx. without cable)

NC 06:	145 lbs. (66Kg)
NC 08:	163 lbs. (74Kg)
NC 10:	170 lbs. (77Kg)

Due to continuous product development, specifications are subject to change without notice.

03.10.Rev.0